

The **PROJECTOR LIFT SI-100** is a versatile and innovative product that enables the installation of projectors in environments where particular aesthetical solutions are needed.

The product has been developed to be installed inside false ceilings in order to hide projector, lift and cables, thus granting the best aesthetic and practical solution.

The **SI-100** is supplied with an extremely **SILENT** motor that allows a descent from a minimum of 16 cm. to a maximum of 90 cm.



**PROJECTOR LIFT
PARTLY OPEN**

Forhandler:
AV-Concept ApS
Tlf: 30321889
Mail: info@av-concept.dk
www.av-concept.dk

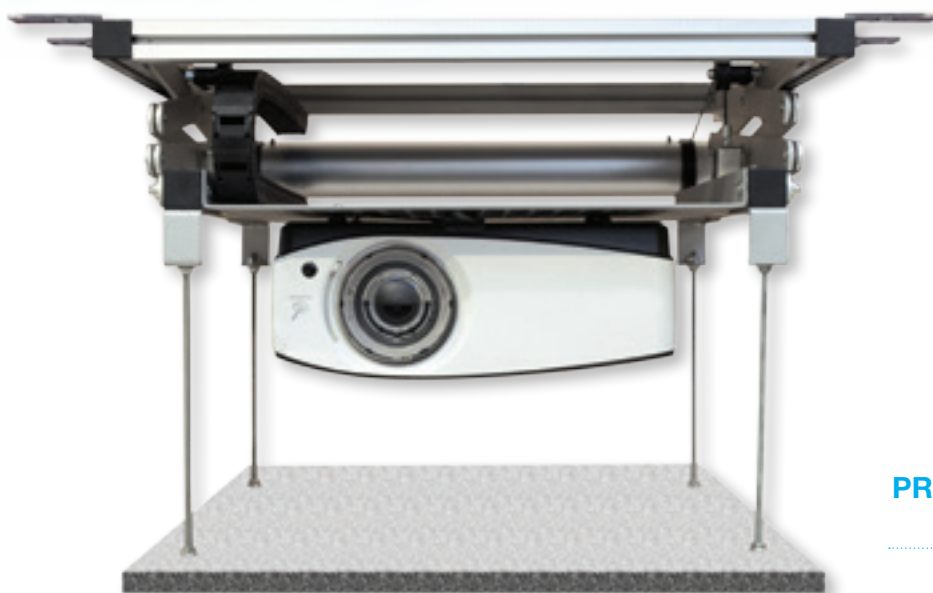

**PROJECTOR LIFT
CLOSED**

Moreover, the SI-100 is supplied with a particular system that allows an easy fixing of a panel of your false ceiling by the threaded bars whose height adjustable. One more interesting element of this lift is a **CABLES**

GATHERING SYSTEM with a raceway where to put the cables of the projector, so they will be hidden and tidy gathered together when the projector lift is going up.

TECHNICAL SPECIFICATIONS

• POWER SUPPLY	220-230 V 50 HZ
• MAXIMUM CONSUMPTION	156 W
• TORQUE	10 Nm
• MOTOR SPEED	17 Rpm
• DIMENSIONS LIFT CLOSED	576x145x555 (WxHxD in mm.)
• DIMENSIONS LIFT OPENED	576x960x555 (WxHxD in mm.)
• GRILLE TOTAL DIMENSIONS	410x450 (WxD in mm.)
• GRILLE INTERNAL DIMENSIONS	350x450 (WxD in mm.)
• MAXIMUM SIZE FIXING POINTS OF PROJECTOR	320X350 (WxD in mm.)
• MAXIMUM CAPACITY	15 KG.
• NET WEIGHT OF THE PROJECTOR LIFT	12 KG.
• CABLE GATHERING SYSTEM (internal dimensions)	20x18 (WxH in mm.)

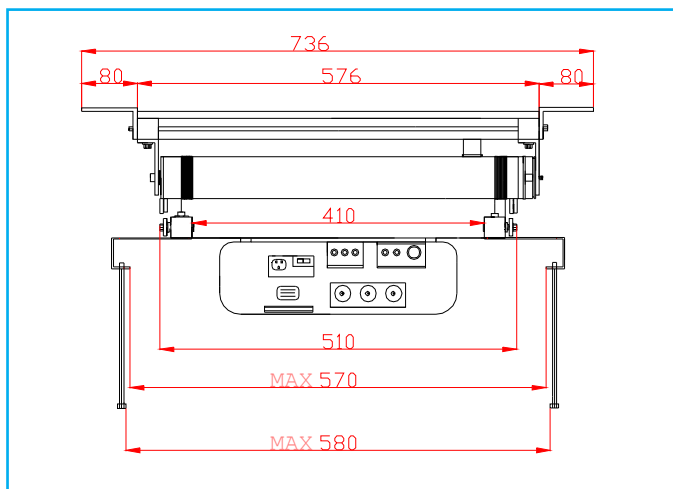

CLOSED LIFT: FRONTAL VIEW

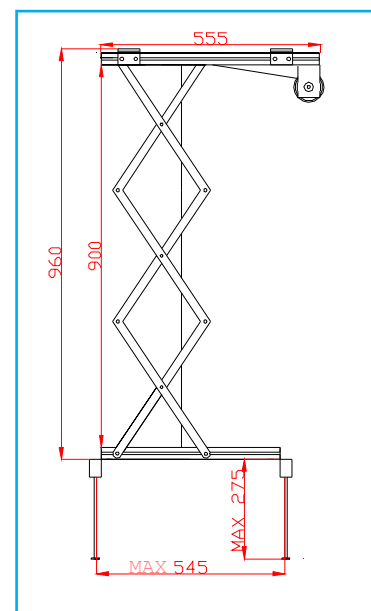

OPEN LIFT: SIDE VIEW

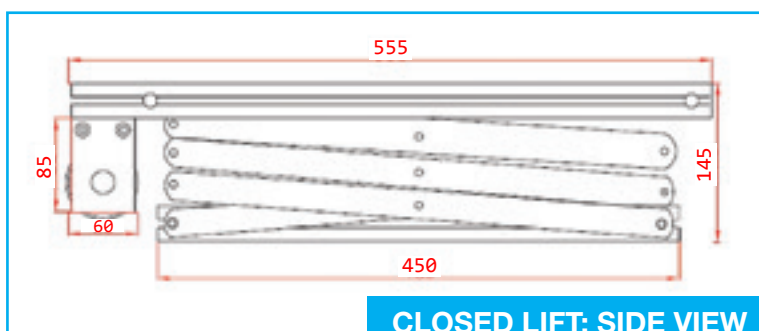

CLOSED LIFT: SIDE VIEW

* The measures of the drawings are expressed in millimetres.

Forhandler:
AV-Concept ApS
Tlf: 30321889
Mail: info@av-concept.dk
www.av-concept.dk

Euroscreen S.r.l.
Via Stiria, 45/16 - 33100 Udine - Italy
Tel. +39 0432 522755
Fax +39 0432 524000
www.screenint.com
info@screenint.com

